

**FOR ADDITIONAL
INFORMATION ON ISUZU'S FULL
LINE OF LOW CAB FORWARD
TRUCKS PLEASE VISIT**

ISUZU

**WWW.ISUZUTRUCK.CA
OR CALL (866) 441-9638**



**SCAN TO ACCESS A
DIGITAL COPY OF THE 2027
FULL-LINE POCKET GUIDE**



2027 MY

FULL-LINE POCKET GUIDE

ISUZU

All photographs, illustrations, equipment, and technical data in this brochure are based on the latest information available at the time of publication. Isuzu Commercial Truck of Canada, Inc. reserves the right to make changes at any time, without notice, in prices, colors, materials, equipment, specifications, and models, and to discontinue models or equipment. Isuzu vehicles are assembled from component parts manufactured by Isuzu Motors Limited, its affiliated companies, and by independent suppliers who manufacture such components to Isuzu's exacting standards for quality, performance, and safety. Some vehicles are shown with optional equipment. Some equipment is dealer installed. Visit your authorized Isuzu dealer for warranty and other details. Facebook logo is a registered trademark of Meta, Instagram logo is a registered trademark of Meta, X logo is a trademark of X Corp, YouTube logo is a registered trademark of Google Inc., The Toki logo is a registered trademark of Byredance Ltd, LinkedIn logo is a registered trademark of LinkedIn Corporation. Neither Isuzu Commercial Truck of Canada, Inc. nor Isuzu Motors Limited are sponsored by or affiliated with these platforms. Cummins and the Cummins logo are registered trademarks of Cummins Inc. Allison, the Allison Transmission logo, and Transmission Series are registered trademarks of Allison Transmission Inc. Mobileye is a registered trademark of Mobileye Global Inc. FleetValue is a registered trademark of Isuzu Commercial Truck of America, Inc. Isuzu360 is a trademark of Isuzu Commercial Truck of America, Inc. Copyright © 2026 Isuzu Commercial Truck of Canada, Inc.

BENEFITS OF LOW CAB FORWARD

Maneuverability and visibility are what Isuzu low cab forward (LCF) trucks are known for. These two advantages alone make Isuzu trucks easier and safer to drive. Customers also have a choice of body sizes up to 30 feet in length — giving you **more choices, more driver benefits, and less hassle** when navigating the road ahead.

SUPERB MANEUVERABILITY

Isuzu trucks have class-leading turning radiuses which reduce the amount of three-point turns on any given route. Parking and backing into tight places is just easier in an Isuzu LCF truck.

- **More maneuverability.** When equal body sizes are mounted on a conventional cab truck and a low cab forward truck, the low cab forward truck has a shorter overall vehicle length providing **more maneuverability** with equal cargo loads
- Isuzu-built trucks' best-in-class turning radius is achieved with the LCF cab design and the inner wheel cut.

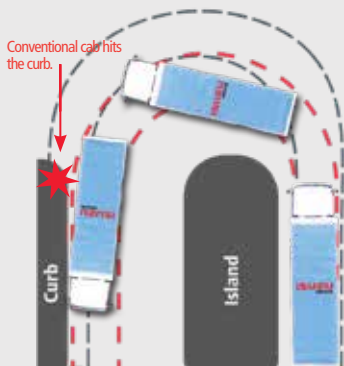

■ Isuzu Trucks' Turning Radius
■ Turning Radius of Conventional Cab

INCREASED FORWARD VISIBILITY

Less forward mass gives the driver and passengers **more visibility** compared to conventional cabs.



EFFICIENT OVERALL LENGTH

Conventional cabs have to be longer in order to accommodate a forward-mounted engine. In contrast, Isuzu LCF cabs are positioned above the engine with **less forward mass**. This efficient design provides **more Cab to Axle (CA) space** compared to conventional cabs with equivalent wheelbases, allowing:

- Up to 4 ft. longer bodies to accommodate **more cargo**
- Body sizes up to 30 ft. in length gives you **more choices**

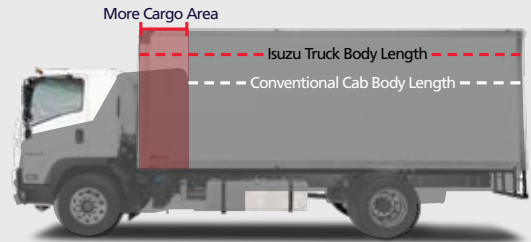

N-SERIES GAS

FOUR MODELS

Built to Move Your Business Forward

Need a dependable truck that works as hard as you do? The 350-hp V8 gas engine with a 280,000-kilometer design life and the durable design of the N-Series chassis is the truck for you. Its low-cab-forward design gives drivers exceptional visibility and maneuverability, making tight spaces and busy routes easier to handle. Available in two cab styles and six wheelbases, it adapts to nearly any business need—offering practicality, reliability, and the capability to keep your operation moving forward.

NPR - Class 3
NPR-HD - Class 4

NQR - Class 5
NRR - Class 5



STANDARD CAB
Seating for 3

CREW CAB
Seating for 7

N-SERIES GAS

NPR

NPR-HD

GVWR	12,000 lbs. <i>(Class 3)</i>	14,500 lbs. <i>(Class 4)</i>
GCWR	18,000 lbs.	20,500 lbs.
FRAME	Ladder type channel section straight frame rail 33.5 inches wide through the total length of the frame. Yield strength 44,000 psi, section modulus 7.20 in ³ , RBM 316,800 lb-in.	
BODY/PAYLOAD ALLOWANCE <ul style="list-style-type: none">▪ STANDARD▪ CREW CAB	6,667 lbs. - 6,846 lbs. 6,115 lbs. - 6,166 lbs.	8,826 lbs. - 8,986 lbs. 8,277 lbs. - 8,318 lbs.
GAWR (FRONT/REAR)	4,860 lbs./8,840 lbs.	6,630 lbs./11,020 lbs.
AXLE CAPACITY (FRONT/REAR)	6,830 lbs./14,550 lbs.	6,830 lbs./14,550 lbs.
REAR AXLE RATIO	3.909	4:100
SUSPENSION (FRONT/REAR) <ul style="list-style-type: none">▪ TYPE▪ CAPACITY	Tapered/Multi-Leaf 6,830 lbs./12,900 lbs.	Tapered/Multi-Leaf 6,830 lbs./12,900 lbs.
V8 GASOLINE ENGINE <ul style="list-style-type: none">▪ TYPE▪ DISPLACEMENT▪ HORSEPOWER▪ TORQUE	GMPT L8T (Gen V) 6.6L (400 cu.in.) 350hp @ 4,500 rpm 425 lb.-ft. @ 3,800 rpm	GMPT L8T (Gen V) 6.6L (400 cu.in.) 350hp @ 4,500 rpm 425 lb.-ft. @ 3,800 rpm
TRANSMISSION	8L90 Hydra-Matic 8-speed automatic with lock-up converter and overdrive	8L90 Hydra-Matic 8-speed automatic with lock-up converter and overdrive
BRAKES <ul style="list-style-type: none">▪ SERVICE	Vacuum+Power Assist/ Hydraulic with 4-Channel ABS/Front and Rear Disc	Vacuum+Power Assist/ Hydraulic with 4-Channel ABS/Front and Rear Disc
LIMITED SLIP DIFFERENTIAL	Optional	Optional
ALTERNATOR	170-amp	170-amp
BATTERIES	1 Maintenance-Free Group 31750-CCA	1 Maintenance-Free Group 31750-CCA
TIRES LRR (Low Rolling Resistance)	215/85R16E (10-pr)	225/70R19.5G (14-pr)
FUEL TANK	38.6-gal. in-frame	38.6-gal. in-frame

N-SERIES GAS

NQR

NRR

GVWR	17,950 lbs. <i>(Class 5)</i>	19,500 lbs. <i>(Class 5)</i>
GCWR	23,950 lbs.	25,500 lbs.
FRAME	Ladder type channel section straight frame rail 33.5 inches wide through the total length of the frame. Yield strength 44,000 psi, section modulus 7.20 in ³ , RBM 316,800 lb-in.	
BODY/PAYLOAD ALLOWANCE		
▪ STANDARD	11,665 lbs. - 12,064 lbs.	13,166 lbs. - 13,611 lbs.
▪ CREW CAB	11,105 lbs. - 11,471 lbs.	12,606 lbs. - 13,018 lbs.
GAWR (FRONT/REAR)	6,830 lbs./13,660 lbs.	7,275 lbs./14,460 lbs.
AXLE CAPACITY (FRONT/REAR)	6,830 lbs./14,550 lbs.	7,275 lbs./14,550 lbs.
REAR AXLE RATIO	5.375	5.375
SUSPENSION (FRONT/REAR)		
▪ TYPE	Tapered/Multi-Leaf	Tapered/Multi-Leaf
▪ CAPACITY	8,440 lbs./14,550 lbs.	8,440 lbs./14,550 lbs.
V8 GASOLINE ENGINE		
▪ TYPE	GMPT L8T (Gen V)	GMPT L8T (Gen V)
▪ DISPLACEMENT	6.6L (400 cu.in.)	6.6L (400 cu.in.)
▪ HORSEPOWER	350hp @ 4,500 rpm	350hp @ 4,500 rpm
▪ TORQUE	425 lb.-ft. @ 3,800 rpm	425 lb.-ft. @ 3,800 rpm
TRANSMISSION	Allison 1000 RDS 6-speed automatic	Allison 1000 RDS 6-speed automatic
BRAKES		
▪ SERVICE	Vacuum+Power Assist/ Hydraulic with 4-Channel ABS/Front and Rear Disc	Vacuum+Power Assist/ Hydraulic with 4-Channel ABS/Front and Rear Disc
LIMITED SLIP DIFFERENTIAL	Optional	Optional
ALTERNATOR	170-amp	170-amp
BATTERIES	1 Maintenance-Free Group 31750-CCA	1 Maintenance-Free Group 31750-CCA
TIRES LRR (Low Rolling Resistance)	225/70R19.5G (14-pr)	225/70R19.5G (14-pr)
FUEL TANK	38.6-gal. in-frame	38.6-gal. in-frame

N-SERIES GAS

STANDARD CAB

Wheelbase (in.)	Cab to Axle (in.)	Cab to End of Frame (in.)
109.0 [†]	86.5	129.6
132.5	110	153.1
150.0	127.5	170.6
176.0	153.5	196.6
200.0 ^{††}	177.5	220.6
212.0 ^{†††}	189.5	232.6

OAL (in.)	OAH (in.)	OAW (in.)	Body Length (ft.)
200.5	92.4*	81.3	10-12
224.0	92.4*	81.3	12-14
241.5	92.4*	81.3	16-18
267.5	92.4*	81.3	18-20
291.5	92.4*	81.3	22
303.5	92.4*	81.3	24

CREW CAB

150.0	88.5	131.6
176.0	114.5	157.6
200.0 ^{††}	138.5	181.6
212.0 ^{†††}	150.5	193.6

241.5	92.4**	81.3	12
267.5	92.4**	81.3	16
291.5	92.4**	81.3	18
303.5	92.4**	81.3	20

[†]NPR, NPR-HD only

^{††}NQR and NRR only

^{†††}NRR only

*NPR Standard Cab is 90 in. and NPR-HD Standard Cab is 90.9 in.

**NPR Crew Cab is 90 in. NPR-HD Crew Cab is 91.1 in.

*NPR Standard Cab is 90 in. and NPR-HD Standard Cab is 90.9 in.

**NPR Crew Cab is 90 in. NPR-HD Crew Cab is 91.1 in.

Frame Height

Standard Cab	33*
Crew Cab	33*

Frame Rail Width

Standard Cab	33.5
Crew Cab	33.5

Back of Cab

Standard Cab	77
Crew Cab	5

Afterframe

Standard Cab	431
Crew Cab	431

*NPR is 31.8

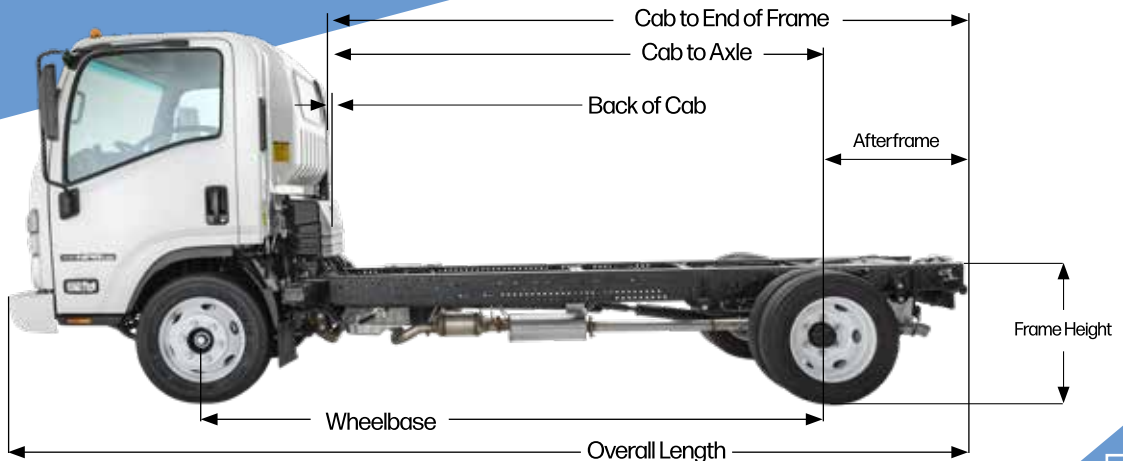

N-SERIES GAS

CLASS 3 & 4 WEIGHTS

STANDARD CAB

	NPR		
Wheelbase (in.)	Curb Weight (lbs.)	Body Payload (lbs.)	Model Codes
109.0	5,154	6,846	1C1
132.5	5,256	6,744	1C2
150.0	5,285	6,715	1C3
176.0	5,333	6,667	1C4

NPR-HD		
Curb Weight (lbs.)	Body Payload (lbs.)	Model Codes
5,514	8,986	1F1
5,593	8,907	1F2
5,633	8,867	1F3
5,674	8,826	1F4

CREW CAB

150.0	5,834	6,166	1D3
176.0	5,885	6,115	1D4

6,182	8,318	1G3
6,223	8,277	1G4

CLASS 5 WEIGHTS

STANDARD CAB

	NQR		
Wheelbase (in.)	Curb Weight (lbs.)	Body Payload (lbs.)	Model Codes
132.5	5,886	12,064	1R2
150.0	5,929	12,021	1R3
176.0	5,983	11,967	1R4
200.0	6,285	11,665	1R5
212.0	N/A	N/A	N/A

NRR		
Curb Weight (lbs.)	Body Payload (lbs.)	Model Codes
5,889	13,611	1U2
5,932	13,568	1U3
5,986	13,514	1U4
6,288	13,212	1U5
6,334	13,166	1U6

CREW CAB

150.0	6,479	11,471	1S3
176.0	6,543	11,407	1S4
200.0	6,845	11,105	1S5
212.0	N/A	N/A	N/A

6,482	13,018	1V3
6,546	12,954	1V4
6,848	12,652	1V5
6,894	12,606	1V6

N-SERIES GAS

ACCESSORIES & OPTIONS

- Air Deflector
- Back Up Alarm
- Dual AGM Batteries (825 CCA x 2)
- Dual Batteries (750CCA x 2)
- Chrome Grille
- Heated Mirrors
- Power Heated Mirrors
- High-Visibility Seatbelts
- Spare Keys (2 additional keys)
- Speed Limiting to 104 kph
- Driver's Suspension Seat
- 102-in. Side Mirror Bracket



Mobileye®

High-Visibility Seatbelts

Touchscreen Audio

- Keyless Entry
- Mobileye®
- Limited Slip Differential (LSD)
- Touchscreen Audio System with Back Up Camera
- Seat Covers

N-SERIES GAS

NPR & NPR-HD

New Vehicle Limited Warranty

Warranty Limitations: Time or Kilometrage, Whichever Comes First

New Vehicle Warranty	Years	Kilometers
Basic	3	60,000
Engine Transmission - 8L-90 Drivetrain	5	120,000
Frame Rails	3 5*	60,000 Unlimited*
Corrosion (Rust-Through)	4	Unlimited
Roadside Assistance	3 5†	60,000 120,000†
Emission Warranty	Years	Kilometers
Emissions Control System - Federal	5	80,000
GHG Emission	5	80,000
Tire	2	38,000

* After 3 years or 60,000 kilometers (whichever comes first), labor and parts coverage is 50% for up to 5 years.

† Tows related to emissions issues may be covered for up to 5 years or 80,000 kilometers (whichever comes first).

**Please see warranty booklet for coverage details.

The warranty coverages are determined by the kilometrage of the vehicle and the number of years from the delivery date. The warranty coverages are limited by whichever occurs first. Please see your authorized Isuzu dealer for warranty details.

EXTENDED WARRANTY

60 MONTHS/240,000 Kilometers

(See Your Authorized Isuzu Dealer for Additional Extended Warranty Coverages)

ENGINE

All internally lubricated parts including, but not limited to, cylinder block, head, oil pan, thermostat housing, flywheel, intake manifolds, and the following internal parts: Oil pump, pistons with rings, crankshaft and bearings, connecting rods and bearings, head bolts, cylinder head gasket, intake and exhaust valves, rocker arm assembly, camshaft actuator, camshaft, front and rear main seals.

DRIVE AXLE

Differential, axle shafts, all seals and bearings.

TRANSMISSION

Transmission case and all internal parts.

ROADSIDE ASSISTANCE

Roadside assistance and towing to the nearest dealer for covered repairs on the vehicle at no additional charge.

N-SERIES GAS

NQR & NRR

New Vehicle Limited Warranty

Warranty Limitations: Time or Kilometrage, Whichever Comes First

New Vehicle Warranty	Years	Vehicle Kilometers
Basic	3	60,000
Engine Drivetrain	5	120,000
Transmission - Allison*	5	Unlimited
Frame Rails	3 5**	60,000 Unlimited***
Corrosion (Rust-Through)	4	Unlimited
Roadside Assistance	3 5†	60,000 120,000†
Emission Warranty	Years	Vehicle Kilometers
Federal Defect	5	80,000
GHG Emission	5	80,000
Tire	2	38,000

*The Allison automatic transmission is warranted separately by Allison Transmission. The warranty coverages are determined by the kilometrage of the vehicle and the number of years from the delivery date. The warranty coverages are limited by whichever occurs first. Please see your authorized Isuzu dealer for warranty details.

**After 3 years or 60,000 kilometers (whichever comes first), labor and parts coverage is 50% for up to 5 years.

†Tows related to emissions issues may be covered for up to 5 years or 80,000 kilometers (whichever comes first).

EXTENDED WARRANTY

60 MONTHS/240,000 Kilometers

(See Your Authorized Isuzu Dealer for Additional Extended Warranty Coverages)

ENGINE

All internally lubricated parts including, but not limited to, cylinder block, head, oil pan, thermostat housing, flywheel, intake manifolds, and the following internal parts: Oil pump, pistons with rings, crankshaft and bearings, connecting rods and bearings, head bolts, cylinder head gasket, intake and exhaust valves, rocker arm assembly, camshaft actuator, camshaft, front and rear main seals.

DRIVE AXLE

Differential, axle shafts, all seals and bearings.

ROADSIDE ASSISTANCE

Roadside assistance and towing to the nearest dealer for covered repairs on the vehicle at no additional charge.

*The transmission is not covered under this extended warranty.

ISUZU



Model shown: NRR Diesel

N-SERIES DIESEL

THREE MODELS

NPR-HD - Class 4
NPR-XD - Class 4

NRR* - Class 5

Built for the Long Haul

The 600,000-kilometer B10 rating of the Isuzu 5.2-liter turbocharged diesel engine is a testament to the N-Series Diesel durability. The low-cab forward design is engineered for the long haul and the tight turns, making city streets and heavy loads easier to manage. The driver-inspired cab combines comfort, technology, and safety for an enhanced driving experience. Whatever your vocation, the N Series Diesel delivers the reliability and efficiency that keep businesses moving forward.



STANDARD CAB
Seating for 3

CREW CAB
Seating for 7

**Can be Derated to 17,950 lbs.*

N-SERIES DIESEL

NPR-HD

NPR-XD

GVWR	14,500 lbs. (Class 4)	16,000 lbs. (Class 4)
GCWR	20,500 lbs.	22,000 lbs.
FRAME ▪ STANDARD ▪ CREW CAB	Ladder type channel section straight frame rail 33.5 in wide through the total length of the frame. Yield strength 54,800 psi section modulus 6.65 cubic in, RBM 364,420 lb-in per rail. Ladder type channel section straight frame rail 33.5 in wide through the total length of the frame. Yield strength of 54,800 psi, section modulus 11.87 cubic in, RBM 576,350 lb-in per rail.	
BODY/PAYLOAD ALLOWANCE ▪ STANDARD ▪ CREW CAB	8,327 lbs. - 8,470 lbs. 7,725 lbs. - 7,776 lbs.	9,430 lbs. - 9,576 lbs. 8,831 lbs. - 8,879 lbs.
GAWR (FRONT/REAR)	5,360 lbs./9,880 lbs.	6,630 lbs./11,020 lbs.
AXLE CAPACITY (FRONT/REAR)	6,830 lbs./11,020 lbs.	6,830 lbs./11,020 lbs.
REAR AXLE RATIO	4.556	4.777
SUSPENSION (FRONT/REAR) ▪ TYPE ▪ CAPACITY	Tapered/Multi-Leaf 6,830 lbs./9,880 lbs.	Tapered/Multi-Leaf 8,440 lbs./14,308 lbs.
TURBOCHARGED DIESEL ENGINE ▪ TYPE ▪ DISPLACEMENT ▪ HORSEPOWER ▪ TORQUE	Isuzu 4HK1-TC 5.2L (317 cu.in.) 215hp @ 2,500 rpm 452 lb.-ft. @ 1,850 rpm	Isuzu 4HK1-TC 5.2L (317 cu.in.) 215hp @ 2,500 rpm 452 lb.-ft. @ 1,850 rpm
TRANSMISSION	Aisin A465id 6-speed auto. with double overdrive and lock-up 2nd-6th gears	Aisin A465id 6-speed auto. with double overdrive and lock-up 2nd-6th gears
BRAKES ▪ SERVICE ▪ EXHAUST	Vacuum+Power Assist/ Hydraulic with 4-Channel ABS/Front and Rear Disc Standard	Vacuum+Power Assist/ Hydraulic with 4-Channel ABS/Front and Rear Disc Standard
STABILITY CONTROL	Standard - Electronic Stability Control (ESC) with Anti-Slip Regulation (ASR)	Standard - Electronic Stability Control (ESC) with Anti-Slip Regulation (ASR)
ALTERNATOR	140-amp	140-amp
BATTERIES	2 Maintenance-Free Group 31750-CCA	2 Maintenance-Free Group 31750-CCA
TIRES LRR (Low Rolling Resistance)	215/85R16E (10-pr)	225/70R19.5F (12-pr)
TIRE PRESSURE MONITORING SYSTEM (TPMS)	Standard	Standard
FUEL TANK ▪ STANDARD	30-gal.in-frame	30-gal.in-frame

N-SERIES DIESEL

NRR DERATE

NRR

GVWR	17,950 lbs. (Class 5)	19,500 lbs. (Class 5)
GCWR	23,950 lbs.	25,500 lbs.
FRAME ▪ STANDARD ▪ CREW CAB	Ladder type channel section straight frame rail 33.5 in wide through the total length of the frame. Yield strength 54,800 psi section modulus 6.65 cubic in, RBM 364,420 lb-in per rail. Ladder type channel section straight frame rail 33.5 in wide through the total length of the frame. Yield strength of 54,800 psi, section modulus 11.87 cubic in, RBM 576,350 lb-in per rail.	
BODY/PAYLOAD ALLOWANCE ▪ STANDARD ▪ CREW CAB	10,969 lbs. - 11,420 lbs. 10,659 lbs. - 10,710 lbs.	12,473 lbs. - 12,970 lbs. 12,209 lbs. - 12,260 lbs.
GAWR (FRONT/REAR)	6,830 lbs./12,980 lbs.	7,275 lbs./13,660 lbs.
AXLE CAPACITY (FRONT/REAR)	7,275 lbs./14,550 lbs.	7,275 lbs./14,550 lbs.
REAR AXLE RATIO	5.571	5.571
SUSPENSION (FRONT/REAR) ▪ TYPE ▪ CAPACITY	Tapered/Multi-Leaf 8,440 lbs./14,550 lbs.	Tapered/Multi-Leaf 8,440 lbs./14,550 lbs.
TURBOCHARGED DIESEL ENGINE ▪ TYPE ▪ DISPLACEMENT ▪ HORSEPOWER ▪ TORQUE	Isuzu 4HK1-TC 5.2L (317 cu. in.) 215hp @ 2,500 rpm 452 lb.-ft. @ 1,850 rpm	Isuzu 4HK1-TC 5.2L (317 cu. in.) 215hp @ 2,500 rpm 452 lb.-ft. @ 1,850 rpm
TRANSMISSION	Aisin A465id 6-speed auto. with double overdrive and lock-up 2nd-6th gears	Aisin A465id 6-speed auto. with double overdrive and lock-up 2nd-6th gears
BRAKES ▪ SERVICE ▪ EXHAUST	Vacuum+Power Assist/ Hydraulic with 4-Channel ABS/Front and Rear Disc Standard	Vacuum+Power Assist/ Hydraulic with 4-Channel ABS/Front and Rear Disc Standard
STABILITY CONTROL	Standard - Electronic Stability Control (ESC) with Anti-Slip Regulation (ASR)	Standard - Electronic Stability Control (ESC) with Anti-Slip Regulation (ASR)
ALTERNATOR	140-amp	140-amp
BATTERIES	2 Maintenance-Free Group 31750-CCA	2 Maintenance-Free Group 31750-CCA
TIRES LRR (Low Rolling Resistance)	225/70R19.5F (12-pr)	225/70R19.5F (12-pr)
TIRE PRESSURE MONITORING SYSTEM (TPMS)	Standard	Standard
FUEL TANK ▪ STANDARD	30-gal. in-frame	30-gal. in-frame

N-SERIES DIESEL

STANDARD CAB

Wheelbase (in.)	Cab to Axle (in.)	Cab to End of Frame (in.)
109.0	86.5	129.6
132.5	110	153.1
150.0	127.5	170.6
176.0	153.5	196.6
200.0 [†]	177.5	220.6
212.0 [†]	189.5	232.6

OAL (in.)	OAH (in.)	OAW (in.)	Body Length (ft.)
195.7	92.9*	81.3	10-12
219.2	92.9*	81.3	12-14
236.7	92.9*	81.3	16-18
262.7	92.9*	81.3	18-20
286.7	92.9	81.3	22
298.7	92.9	81.3	24

CREW CAB

150.0	88.5	131.6
176.0	114.5	157.6

236.7	92.4*	81.3	12
262.7	92.4*	81.3	16

[†]NRR only

*NPR-HD is 90.5 in.

Frame Height

NPR-HD	31.6
NPR-XD & NRR	33.5

Frame Rail Width

Standard Cab	33.5
Crew Cab	33.5

Back of Cab

Standard Cab	7.7
Crew Cab	5.3

Afterframe

Standard Cab	43.1
Crew Cab	43.1

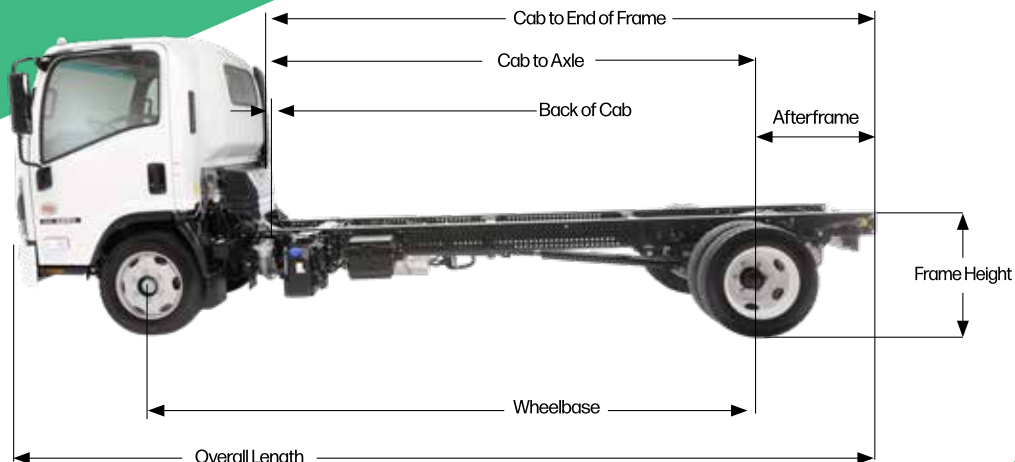

N-SERIES DIESEL

CLASS 4 WEIGHTS

STANDARD CAB

	NPR-HD		
Wheelbase (in.)	Curb Weight (lbs.)	Body Payload (lbs.)	Model Codes
109.0	6,030	8,470	3F1
132.5	6,100	8,400	3F2
150.0	6,133	8,367	3F3
176.0	6,173	8,327	3F4

NPR-XD		
Curb Weight (lbs.)	Body Payload (lbs.)	Model Codes
6,424	9,576	3Y1
6,497	9,503	3Y2
6,528	9,472	3Y3
6,570	9,430	3Y4

CREW CAB

150.0	6,724	7,776	3G3
176.0	6,775	7,725	3G4

7,121	8,879	3Z3
7,169	8,831	3Z4

CLASS 5 WEIGHTS

STANDARD CAB

	NRR DERATE*		
Wheelbase (in.)	Curb Weight (lbs.)	Body Payload (lbs.)	Model Codes
109.0	6,530	11,420	3U1*
132.5	6,612	11,338	3U2*
150.0	6,632	11,318	3U3*
176.0	6,679	11,271	3U4*
200.0	6,981	10,969	3U5*
212.0	N/A*	N/A*	3U6*

NRR		
Curb Weight (lbs.)	Body Payload (lbs.)	Model Codes
6,530	12,970	3U1
6,612	12,888	3U2
6,632	12,868	3U3
6,679	12,821	3U4
6,981	12,519	3U5
7,027	12,473	3U6

CREW CAB

150.0	7,240	10,710	3V1*
176.0	7,291	10,659	3V2*

7,240	12,260	3V3
7,291	12,209	3V4

*NRR Derate is a PIO option.

N-SERIES DIESEL

ACCESSORIES & OPTIONS

- Advanced Driver Assistance System (ADAS) with Electronic Parking Brake
- AGM Batteries (825 CCA x 2)
- Air Deflector
- Back Up Alarm
- Chrome Grille
- Derate GVWR to 17,950-lbs.
- Dual Fuel Tank
- Heated Mirrors
- Power Heated Mirrors
- High-Visibility Seatbelts
- LED Fog Lamps
- LED Tail Lights
- Lockable DEF Cap
- PTO Switch
- Touchscreen Audio System with Back Up Camera
- Seat Covers
- Spare Keys (2 additional keys)



Touchscreen Audio System



Electronic Parking Brake



ADAS System



Lockable DEF Cap

- Emergency Engine Shutdown
- Engine Idle Shutdown (3 or 5 minutes)
- FMS Jumper Harness provides read-only CAN data for compatible telematics systems
- Speed Limiting to 96, 104, 109 or 112 km/h
- Driver's Suspension Seat
- Vertical Exhaust
- 102-in. Side Mirror Bracket

N-SERIES DIESEL

New Vehicle Limited Warranty

Warranty Limitations: Time or Kilometrage, Whichever Comes First

New Vehicle Warranty	Years	Kilometers
Basic	3	Unlimited
Engine	3	Unlimited
Transmission - Aisin A465ID	3	Unlimited
Drivetrain	3	Unlimited
Frame/Rails	3 5*	Unlimited Unlimited*
Corrosion (Rust Through)	4	Unlimited
Roadside Assistance	3 5 [†]	Unlimited 160,000 [†]
Emission Defect	Years	Kilometers
Emission Defect Warranty	5	177,000
GHG Emission	5	80,000
Tire	2	38,000
Tire Pressure Monitoring System	5	80,000

*After 3 years labor and parts coverage is 50% for up to 5 years.

[†]Tows related to emissions issues may be covered for up to 5 years or 177,000 kilometers (whichever comes first).

The warranty coverages are determined by the kilometrage of the vehicle and the number of years from the delivery date. The warranty coverages are limited by whichever occurs first. Please see your authorized Isuzu dealer for warranty details.

EXTENDED WARRANTY

60 MONTHS / 280,000 Kilometers

(See Your Authorized Isuzu Dealer for Additional Extended Warranty Coverages)

ENGINE

All internally lubricated parts including, but not limited to, cylinder block, cylinder head, oil pan, oil cooler, thermostat housing, flywheel, intake manifolds, and the following internal parts: Timing gear, Front and main seals, Oil pump, pistons with rings, liners, crankshaft and bearings, connecting rods and bearings, head bolts, cylinder head gasket, intake and exhaust valves, rocker arm assembly, camshaft and bearings.

DRIVE AXLE

Differential, axle shafts, all seals and bearings

TRANSMISSION

Transmission case and all internal parts

ROADSIDE ASSISTANCE

Roadside assistance and towing to the nearest dealer for covered repairs on the vehicle at no additional charge

NRR EV

Zero Emissions. Zero Compromises.

The Isuzu N-Series EV brings the future of commercial trucking to today's businesses with quiet, zero-emission power and the same trusted capability the N-Series is known for. Built on a Class 5 platform with a 19,500-lb GVWR, it delivers smooth, confident performance through a fully electric powertrain designed for real-world routes and demanding payloads.

CLASS 5 STANDARD CAB Seating for 3



GVWR	19,500 lbs.
BODY/PAYLOAD ALLOWANCE	9,882 lbs. - 12,951 lbs.
GAWR (FRONT/REAR)	7,275 lbs./14,460 lbs.
ELECTRIC MOTOR	ZF CeTrax Lite 3-phase AC motor; motor sub-assembly includes an integrated DC-AC inverter, single speed reduction gear, and motor control unit
MAX POWER / TORQUE OUTPUT	150 kW / 280 lb-ft.
OPERATING VOLTAGE	350 volts
HIGH VOLTAGE BATTERY PACKS	Liquid cooled lithium-ion high voltage battery packs: each pack features 20 kWh of battery capacity
REGENERATIVE BRAKING	Adjustable regenerative braking with multiple strength levels using the steering wheel stalk switch
AC CHARGING	AC charging from SAEJ1772 chargers up to 19.2 kW (limited to 7.2 kW on 60 kWh chassis)
DC FAST CHARGING	DC fast charging from CCS1 chargers up to 80 kW

ELECTRICAL	Two 12-volt (Group 34) 700 CCA
WHEELS	19.5 x 6.0 6-hole disc wheels, painted white
TIRES (FRONT/REAR)	225/70R-19.5 LRR tubeless steel belted radials, all season
BRAKES	Dual circuit power assisted hydraulic 4-channel anti-lock service brake system with electronic brake distribution for load proportioning of the front and rear disc brakes, and a driveshaft mounted drum type electronically actuated parking brake
FRAME	Ladder type channel section straight frame rail 33.5-in. wide through the total length of the frame; yield strength 54,800 psi, section modulus 6.65 cubic in, RBM 364,420 lb-in per rail
ELECTRIC POWER TAKE OFF (ePTO)	Supplies high voltage (350 V) DC power for vocational equipment. Provides 7 kW of continuous power and up to 12 kW instantaneous peak loads.

NRR EV

Wheelbase (in.)	Cab to Axle (in.)	Cab to End of Frame (in.)
132.5	110	153.1
150.0	127.5	170.6
176.0	153.5	196.6

OAL (in.)	OAH (in.)	OAW (in.)	Body Length (ft.)
219.2	92.4	81.3	12-14
236.7	92.4	81.3	16-18
262.7	92.4	81.3	18-20

WB (in.)	BATTERY PACKS	CURB WEIGHTS (lbs.)		
		FRONT	REAR	TOTAL
132.5	3	4139	2410	6549
150	3	4256	2346	6602
176	3	4452	2247	6699
132.5	5	4547	3016	7563
150	5	4734	2882	7616
176	5	5010	2706	7716
176	7	5268	3416	8684
176	9	5548	4070	9618

WB (in.)	BATTERY PACKS	PAYLOAD (lbs.)
132.5	3	12951
150	3	12898
176	3	12801
132.5	5	11937
150	5	11884
176	5	11784
176	7	10816
176	9	9882

Derating the vehicle reduces payload by 1,550-lbs.

Frame Rail Width 33.5

Back of Cab 7.7 - in.

Afterframe 431

Frame Height 33.5 - in.

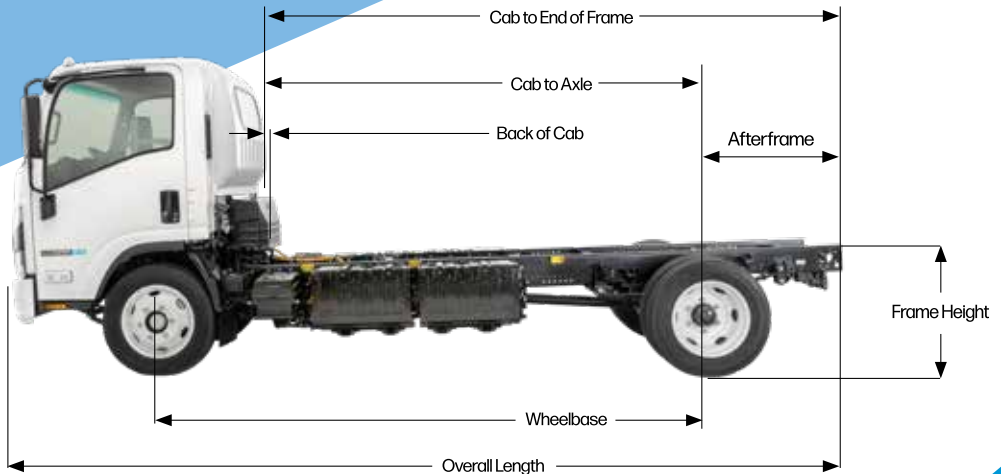

BATTERY CONFIGURATIONS

# Battery Packs	Battery Capacity (kWh)	Wheelbase (in.)	Range (km.)*
3	60	132.5	66-129
		150	
		176	
5	100	132.5	109-209
		150	
		176	
7	140	176	153-290
9	180	176	196-378

*Estimates based on a fully charged battery. For comparison purposes only. Battery capacity decreases with time and use. Actual range will vary based on a number of factors, including number of battery packs, vehicle options, driving conditions and habits, vehicle and battery's condition, and outside temperature.

CHARGING TIMES

	Normal charge (AC)	Rapid charge (DC)
60kWh	7.2 kW 6.5 hours	42 kW 12 hours
100 kWh	19.2 kW 4 hours	70 kW 12 hours
140 kWh	19.2 kW 5.7 hours	80 kW 15 hours
180 kWh	19.2 kW 7.3 hours	80 kW 18 hours

All times are approximate. DC charging time will be longer in cold regions. Please allow up to one hour additional charging time in cold regions. Chart shows the charging times from 20% to 90% state of charge for each battery configuration.

ACCESSORIES & OPTIONS

- Air Deflector
- Back Up Alarm
- Chrome Grille
- Derate GVWR to 17,950-lbs.
- FMS Jumper Harness provides read-only CAN data for compatible telematics systems
- Heated Mirrors
- Power Heated Mirrors
- High-Visibility Seatbelts
- LED Fog Lamps
- Touchscreen Audio System with Back Up Camera
- Seat Covers
- 102-in. Side Mirror Bracket

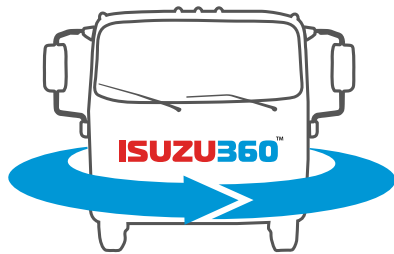

Gasoline- and diesel-powered vehicles allow owners and operators to detect signs of failure from operating sounds and smells. Not so with electric vehicles. But thanks to our exclusive Isuzu360™ telematics service, it's possible to understand the NRR EV's vehicle status and manage charging plans remotely—on your personal computer.

Isuzu360 allows you to monitor—from a distance—the status of every NRR EV in your fleet, including:

- Cruising distance
- Battery level (state of charge)
- Charging status
- Charging history

Isuzu360 provides you access to generate EV reports to meet the requirements of some incentive programs.

Isuzu360 is available at no extra charge on every NRR EV—and it includes all the advantages of Isuzu's outstanding extended electric vehicle warranty coverage.

Isuzu360 is your connection to peace of mind.

DASHBOARD

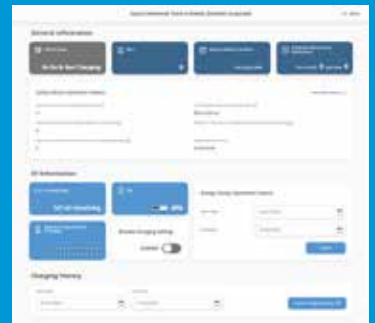

New Vehicle Limited Warranty

Warranty Limitations: Time or Kilometrage, Whichever Comes First

New Truck Warranty	Standard		With Isuzu360 Registration	
	Years	Kilometers	Years	Kilometers
Basic	3	Unlimited	5	Unlimited
Li-Ion Battery	3	93,000	8	249,000
60 kWh		111,000		298,000
100 kWh		130,000		346,000
140 kWh		148,000		394,000
180 kWh				
EV Powertrain Components	3	80,000	8	209,000
Drivetrain	3	Unlimited	3	Unlimited
Frame Rails	3 5*	Unlimited	3 5*	Unlimited
Corrosion - Rust Through	4	Unlimited	4	Unlimited
Greenhouse Gas	5	80,000	5	80,000
Tire	2	38,000	2	38,000
Tire Pressure Monitoring System	5	80,000	5	80,000

*After 3 years, labor and parts coverage is 50% for up to 5 years.

The warranty coverages are determined by the kilometrage of the vehicle and the number of years from the delivery date. The warranty coverages are limited by whichever occurs first.

Please see your authorized Isuzu dealer for warranty details.

Isuzu360™

Sign up with optional Isuzu360, and all recommended scheduled maintenance is

covered for up to five years/160,000 kilometers, whichever occurs first, at no additional charge. See your authorized Isuzu dealer for details.

F-SERIES

Built to Take On the Heavy Jobs

Powered by the proven Cummins B6.7 diesel engine, the Isuzu F-Series delivers the performance and durability fleets count on. With eight wheelbase options, a spacious cab, and plenty of payload, the F-Series gives businesses a versatile, comfortable, and capable truck to keep you moving.

THREE MODELS

- FTR - Class 6**
- FVR DERATE - Class 6**
- FVR - Class 7**



CUMMINS B6.7 L Diesel Engine

- 260-hp
- 660-lb-ft Torque

Allison Transmission

- 2000-Series™
- 6-speed Automatic

F-SERIES

	FTR	FVR DERATE	FVR
GVWR/GCWR	25,950 lbs./30,000 lbs. (Class 6)	25,950 lbs./33,000 lbs. (Class 6)	33,000 lbs./33,000 lbs. (Class 7)
FRAME	Ladder type channel section Yield strength 80,000 psi;	straight frame rail, 33.5 in. wide along the total length of the frame. Section Modulus 12.69 in ³ , RBM 1,015,000 lb-in.	
BODY/PAYLOAD ALLOWANCE	15,062 lbs. - 16,264 lbs.	14,737 lbs. - 15,939 lbs.	21,787 lbs. - 22,989 lbs.
GAWR (FRONT/REAR) LOW PRO	12,000 lbs./19,000 lbs. 11,000 lbs./19,000 lbs.	12,000 lbs./21,000 lbs. N/A	12,000 lbs./21,000 lbs. N/A
AXLE CAPACITY (FRONT/REAR)	12,000 lbs./19,000 lbs.	12,000 lbs./21,000 lbs.	12,000 lbs./21,000 lbs.
REAR AXLE RATIO			
▪ LOW PRO	4.88	N/A	N/A
▪ STANDARD	5.57	5.57	5.57
SUSPENSION (FRONT/REAR)			
▪ TAPERED/MULTI-LEAF (Std.)	12,000 lbs./21,000 lbs.	12,000 lbs./21,000 lbs.	12,000 lbs./21,000 lbs.
▪ TAPERED/AIR (Opt.)	12,000 lbs./23,000 lbs.	12,000 lbs./23,000 lbs.	12,000 lbs./23,000 lbs.
ENGINE			
▪ TYPE	Cummins B6.7 diesel	Cummins B6.7 diesel	Cummins B6.7 diesel
▪ DISPLACEMENT	6.7L (408 cu.in.)	6.7L (408 cu.in.)	6.7L (408 cu.in.)
▪ HORSEPOWER	260hp @ 2,400 rpm	260hp @ 2,400 rpm	260hp @ 2,400 rpm
▪ TORQUE	660 lb.-ft. @ 1,600 rpm	660 lb.-ft. @ 1,600 rpm	660 lb.-ft. @ 1,600 rpm
BRAKES			
▪ SERVICE	Full Air Dual Circuit with ABS S-CAM Drum Automatic Adjust	Full Air Dual Circuit with ABS S-CAM Drum Auto- matic Adjust	Full Air Dual Circuit with ABS S-CAM Drum Automatic Adjust
EXHAUST BRAKE	Standard	Standard	Standard
TRANSMISSION	Allison 2550 RDS 6-speed Automatic (Includes Park Pawl)	Allison 2500 RDS 6-speed Automatic (No Park Pawl)	Allison 2500 RDS 6-speed Automatic (No Park Pawl)
ALTERNATOR	160-amp	160-amp	160-amp
BATTERIES	2 Maintenance-Free Group 31 750-CCA	2 Maintenance-Free Group 31 750-CCA	2 Maintenance-Free Group 31 750-CCA
TIRES LRR (Low Rolling Resistance)	11R22.5G (14-pr)	11R22.5G (14-pr)	11R22.5G (14-pr)
▪ LOW PRO (Opt.)	255/70R22.5H (16-pr)	N/A	N/A
FUEL TANK (LH Side)	50 or 100-gal.	50 or 100-gal.	50 or 100-gal.

F-SERIES

Wheelbase (in.)	Cab to Axle (in.)	Cab to End of Frame (in.)
152	127	1929
170	145	220
188	163	247
200	175	2649
212	187	2831
224	199	301
236	211	3191
248	223	337

OAL (in.)	Afterframe	Body Length (ft.)
2744	65.9	14-16
3015	75	16-18
3285	84.1	18-20
3464	90	20-22
3646	96.1	22-24
3825	102	22-26
4006	108.1	24-28
4185	114	26-30

STANDARD TIRES

FH = Frame height (unladen) at E.O.F. (in.)	
Multi-Leaf	42.5
Air	38.2

FTR OAH Low Pro Tires Multi-leaf/Air (in.)	OAH Standard Tires Multi-leaf/Air (in.)	OAW (in.)
110.2/107	112/108.6	93.5

FTR LOW PRO TIRES

FH = Frame height (unladen) at E.O.F. (in.)	
Multi-Leaf	39.9
Air	35.9

Frame Rail Width (in.)	33.5
Back of Cab (in.)	10.4

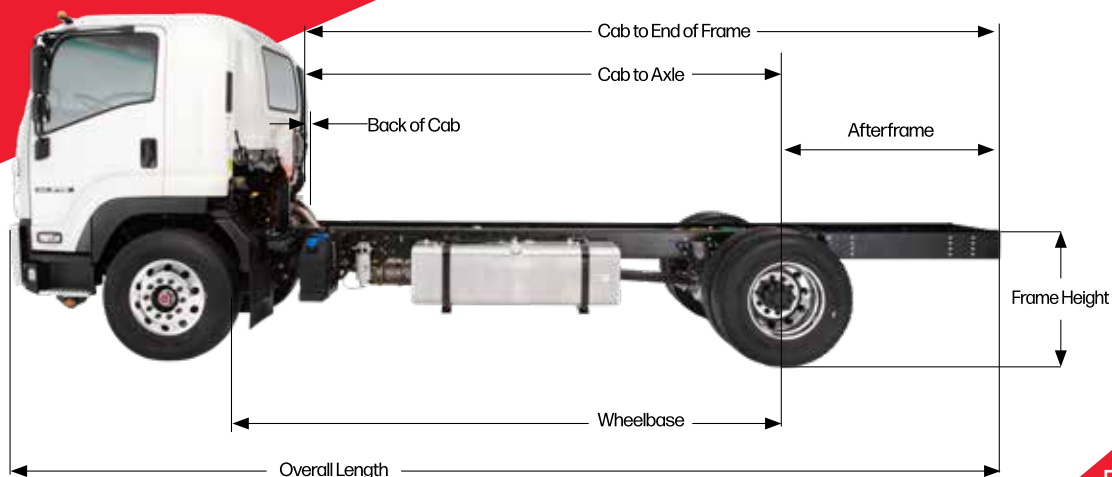

F-SERIES

WEIGHTS

FTR

WB (in.)	Curb Weight (lbs.)	Body Payload (lbs.)	Model Codes
152	9,686	16,264	MT1
170	9,764	16,186	MT2
188	9,947	16,003	MT3
200	10,191	15,759	MT4
212	10,280	15,671	MT5
224	10,524	15,427	MT6
236	10,767	15,184	MT7
248	10,888	15,062	MT8

FVR DERATE

WB (in.)	Curb Weight (lbs.)	Body Payload (lbs.)	Model Codes
152	10,011	15,939	MW1
170	10,089	15,861	MW2
188	10,605	15,346	MW3
200	10,726	15,225	MW4
212	10,849	15,102	MW5
224	10,970	14,981	MW6
236	11,092	14,859	MW7
248	11,213	14,737	MW8



FVR

WB (in.)	Curb Weight (lbs.)	Body Payload (lbs.)	Model Codes
152	10,011	22,989	MV1
170	10,089	22,911	MV2
188	10,605	22,396	MV3
200	10,726	22,275	MV4
212	10,849	22,152	MV5
224	10,970	22,031	MV6
236	11,092	21,909	MV7
248	11,213	21,787	MV8

Curb weights display minimum weight.
Payload weights display maximum weight.

F-SERIES

ACCESSORIES & OPTIONS

- AGM Batteries (825 CCA x 2)
- Air Suspension
- Aluminum Wheels
- Back-Up Alarm
- Chrome Grille
- Emergency Engine Shutdown System
- Engine Idle Shutdown (3 or 5 minutes)
- Low-Pro Tires
- Mobileye®
- Heated Mirrors
- Heated Mirrors with remote adjusting (flat only)
- PTO Switches
- Touchscreen Audio System with Backup Camera
- Seat Covers



Keyless Entry



Aluminum Wheels



Air Suspension



High Visibility Seat Belts

- High-Visibility Seatbelts
- Keyless Entry
- LED Lighting Package (Marker Lights)
- Spare Keys (2 additional keys)
- Speed Limiting to 96, 104, 109 or 112 km/h
- 102-in. Side Mirror Bracket

New Vehicle Limited Warranty

Warranty Limitations: Time or Kilometrage, Whichever Comes First

New Vehicle Warranty	Years	Kilometers
Basic	3	Unlimited
Engine-Cummins*	3	Unlimited
Transmission-Allison**	3	Unlimited
Drivetrain	3	Unlimited
Frame/Rails	3 5†	Unlimited Unlimited†
Corrosion (Rust Through)	4	Unlimited
Roadside Assistance	3 5†	Unlimited 160,000††
Emission Warranty	Years	Kilometers
Emission Component†††	5	160,000
GHG Emission	5	160,000
Tire	2	38,000

*The Cummins engine is warranted separately by Cummins. Please see your authorized Isuzu dealer for available Cummins coverage.

**The Allison automatic transmission is warranted separately by Allison Transmission. Please see your authorized Isuzu dealer for available Allison Transmission coverage.

†After 3 years, coverage is 50% labor and parts for up to 5 years.

††Tows related to emissions issues may be covered for up to 5 years or 160,000 kilometers (whichever comes first).

†††Emission components are covered by either Isuzu or Cummins; see your Isuzu dealer for details.

The warranty coverages are determined by the kilometrage of the vehicle and the number of years from the delivery date. The warranty coverages are limited by whichever occurs first. See your authorized Isuzu dealer for warranty details.

RELIABLE. PREDICTABLE. TRUSTWORTHY.

QUALITY PROGRAMS



Call (866) 441-9659 – 24/7/365 – It is as simple as that when you're in need. Roadside Assistance is standard on all new Isuzu trucks. It covers tows, jump starts, lock outs, and fueling (owner is responsible for cost of fuel). Please see an authorized Isuzu dealer for details.



Your truck's maintenance is vital to keeping it on the road and performing its best. That is why every new Isuzu gas and diesel N-Series truck comes with a complimentary oil coverage plan. This maintenance plan covers lubricating the chassis, replacing the engine fuel filter and checking your tire pressure. Maintenance schedule varies, please see your authorized Isuzu dealer for more information.



Specifically designed replacement parts developed for Isuzu trucks are approved for all warranty repairs and carry a one-year/unlimited-kilometer warranty. See your Isuzu dealer for warranty details.



Isuzu FleetValue Parts are priced to compete with aftermarket parts—but have been engineered to meet Isuzu's stringent specifications and exacting standards for quality, performance, safety, and reliability. And they carry a one-year, unlimited-kilometer warranty.



Preventive maintenance increases your operating efficiency and maximizes your fuel economy. This comprehensive program protects you against increasing labor and parts costs for up to five years. PSMP also guarantees you "Priority" treatment during your service visits and when roadside assistance is needed.

