

N°1 LCF TRUCK IN NORTH AMERICA SINCE 1986



UTILIMASTER REACH™

The Reach™ has what today's business owners want:

- A true commercial-grade vehicle that delivers reliable performance year after year ;
- A timeless style that will still look great ten years from now ;
- A time-efficient design, thanks to its low step-in combined with its pass-through design—drivers can get in and out and back on the road quicker than ever ;
- A Fuel-efficient design with a small carbon footprint. Reach™ is the first in its class to offer Selective Catalytic Reduction (SCR) technology with Diesel Exhaust Fluid (DEF) injection, which reduces NOx levels in engine exhaust by 85% ;
- Powerful, economical and long-lasting engine & powertrain to reduce fuel consumption and engine noise at highway speeds ;
- A lightweight Aerodynamic and shock resistant Van Body, combined with efficient Isuzu diesel powertrain, allow the Reach™ to deliver up to 35% better fuel economy* than a traditional commercial van. The chassis design offers yet other benefits : a tight turning radius that makes maneuvering the Reach™ quick and easy, and a double cargo capacity.

Altogether, these features provide you with a commercial vehicle that can “reach” a wide range of vocations -- everything from package delivery to food distribution, contracting to cleaning services, and moving and storage to heating and air conditioning.

Reach™ is available in two models:

- 151-inch wheelbase with 12-foot body
- 151-inch wheelbase with 14-foot body

* Compared to class 3-5 commercial walk-in vans; testing conducted by independent, certified party.

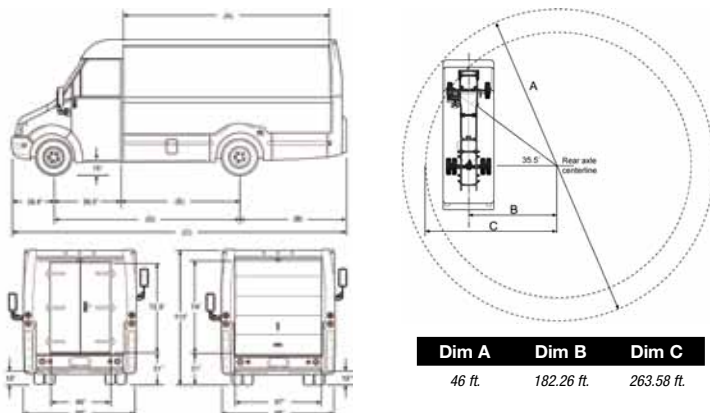

REACH™ WALK IN VAN

GVWR	12 000 lb
PAYLOAD (preliminary)	12ft. @ 3,408 lbs./14ft. @ 3,267 lbs.
GAWR	
Front	5,360 lbs.
Rear	8,840 lbs.
FRONT AXLE CAPACITY	6,830 lbs.
REAR AXLE CAPACITY	11,020 lbs.
Ratio	5.125
SUSPENSION	Tapered/Multi-Leaf
F/R SPRINGS	
Capacity	6,830/9,880 lbs.
FRAME	
Section Modulus	6.07 in. ³
Resistance Bending Moment	267,080 lb.-ft./in.
SERVICE BRAKES	Vacuum/Hydraulic with 4-Channel ABS
Front/Rear	Disc/Drum
EXHAUST BRAKE	Standard
TRANSMISSION	Aisin A460 6-speed auto. with double overdrive and lock-up 2nd-6th gears
ENGINE	Isuzu 4JJ1-TC turbocharged intercooled diesel
Displacement	3.0L (183 in. ³)
Engine Power	150hp @ 2,800 rpm
Engine Torque	282 lb.-ft. @ 1,600-2,800 rpm
Oil Level Indicator	Dash-mounted oil level check switch and light
LIMITED SLIP DIFFERENTIAL	Optional
ALTERNATOR	140-amp
BATTERIES	2 Maintenance-free 750-CCA
TIRES	215/85R16E (10-ply)
STEERING	Integral hydraulic power
STEERING COLUMN	Tilt column
FUEL TANK	25 Gallon in-rail
FUEL/WATER SEPARATOR	Dual fuel filter with dash-mounted indicator light

Reach™ Body Dimensions

Dimension	Description	12'	14'
A	Cargo Floor Length	150,9"	171,0"
B	Behind Rear Axle	69,8"	89,9"
C	Overall Length	260,9"	281,0"
D	Wheel Base	151,0"	151,0"
E	Bulkhead to Axle	94,6"	94,6"



Isuzu Commercial Truck of Canada, Inc.

6205B Airport Road, Suite 410
Mississauga (Ontario) L4V 1E1
Tel.: 905 612.0100 Fax: 905 612.1902
www.isuzutruck.ca